

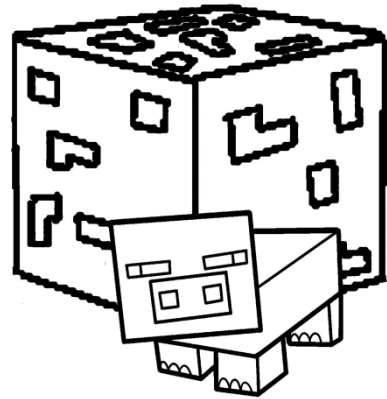

Opuestos verbales: Pinta al cerdo que está adelante

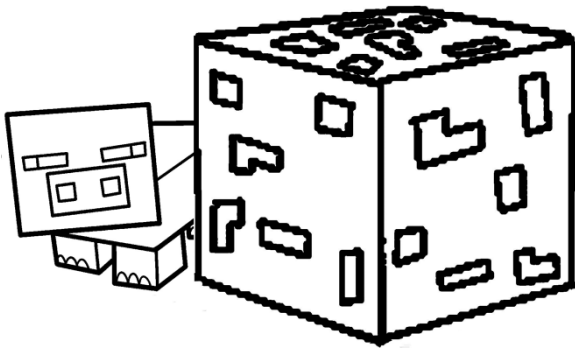

Opuestos verbales: Pinta las arañas que están más arriba, encierra en un círculo las que están más abajo:

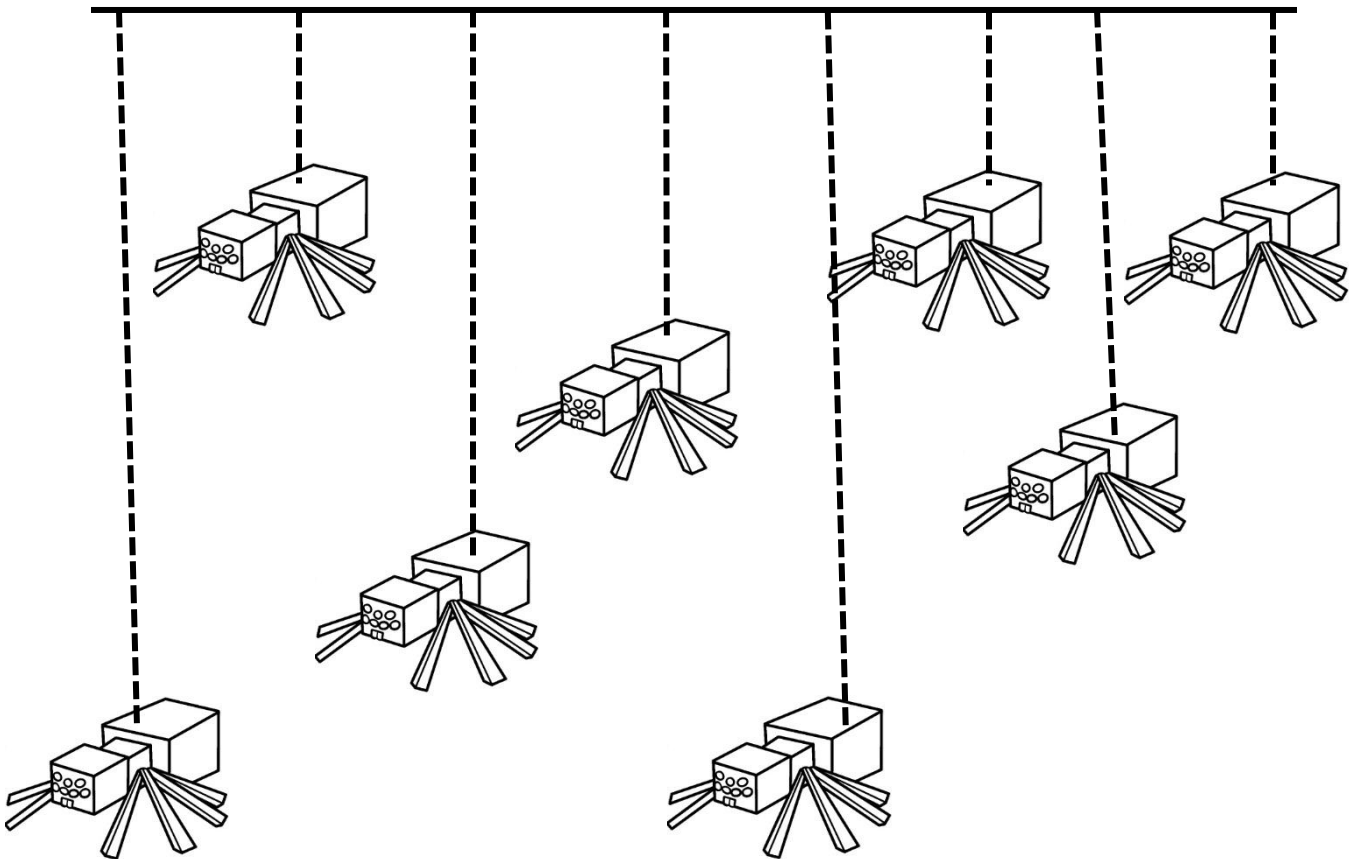



# MINECRAFT

## ACTIVIDADES

Pinta siguiendo las indicaciones:

5	5	5	5	5	5	5	5	5	5	
5	5	6	6	6	6	5	5	5	5	
5	5	8	8	8	6	5	5	5	5	
5	5	6	7	8	7	6	5	5	5	
5	5	8	6	8	6	8	5	5	5	
5	5	8	6	6	6	8	5	5	5	
6	7	7	7	8	7	7	7	6	6	
6	7	7	7	7	7	7	7	6	6	
6	8	8	7	7	7	7	7	8	8	
6	8	8	7	7	7	7	7	8	8	
6	8	8	7	7	7	7	7	8	8	
6	8	8	7	7	7	7	7	8	8	
6	8	8	9	9	7	7	8	8	6	6
6	8	8	9	9	9	9	8	8	6	6
6	6	9	9	9	9	9	6	6	6	6

5 = verde

6 = café

7 = celeste

8 = piel

9 = azul

¿Qué dibujo es? \_\_\_\_\_



# MINECRAFT

## ACTIVIDADES

Pinta las ovejas que son iguales al modelo

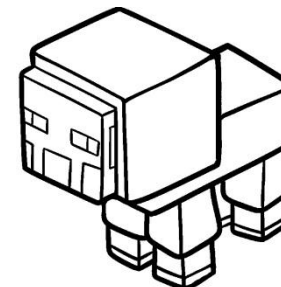
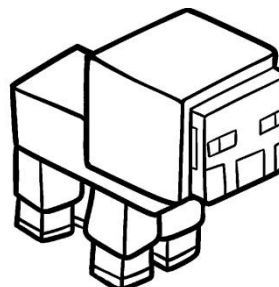
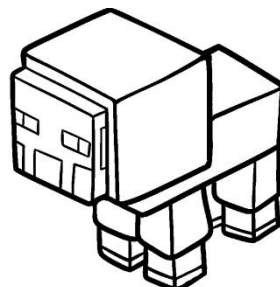
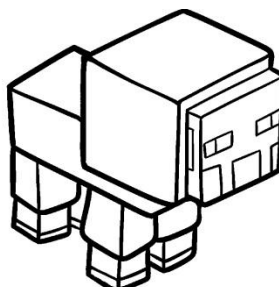
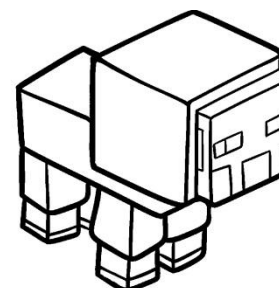
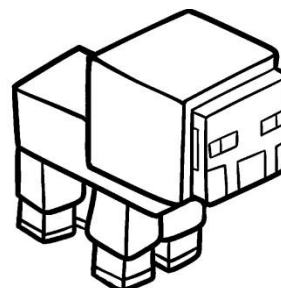
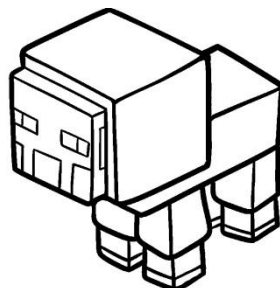
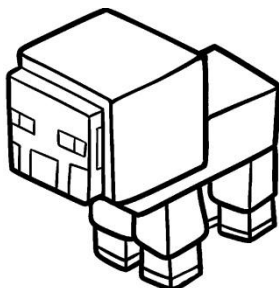
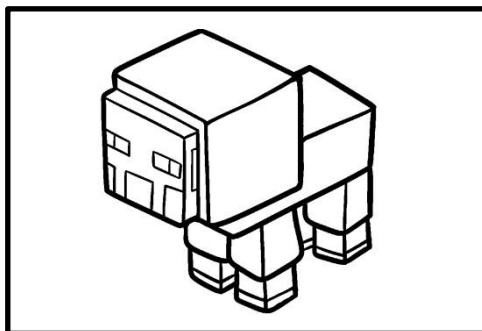



Sigue los laberintos para que los personajes encuentren a los animales:

